



# Crystal Duct System CDS.C

Crystal 50 electrostatic filter section  
for duct installation

# Crystall Duct System CDS.C

Crystall 50 electrostatic filter section for duct installation



**Crystall Duct System** is a fully **customisable\*** innovative filtering system that can be combined with air grids/diffusers, inserted in duct connections through dedicated sections or more simply coupled to ducted terminal units. It is essentially composed of **4 elements**:

- a)** active electrostatic filtering unit Crystall 50 composed of an ionising frame and filter pad
- b)** metal frame with customisable casing based on the types of terminals in the system, for full adaptability
- c)** wired control and power box available fitted on the plenum in the configuration at a distance
- d)** high voltage silicone cable for the connection between filtering plenum and wired box, when remote configuration is requested.

---

(\*) Sabiana's offices are fully available to assess dedicated developments to customer system engineering needs, maximising the achievable filter efficiency performance (@ UNI EN ISO 16890:2017).

Crystall Duct System air purification systems equipped with Sabiana Crystall active electrostatic filter achieve considerable reduction of particulate in the environment thanks to the high filtering efficiency, performance certified by the standard in force UNI EN ISO 16890:2017. Also note that the WHO (World Health Organisation) has classified PM (Particulate Matter) as a group 1 carcinogen as well as carrier of pathogenic biological substances for humans.

Particulate can be solid or liquid: especially liquid aerosols (droplets), such as those produced through breathing and other anthropomorphic activities, are the main carriers of viruses and bacteria that are pathogenic and in some cases lethal to humans.

It is now recognised by the world scientific community that all biological contaminants such as viruses and bacteria are mainly spread by the aerosol produced in the environment by infected people through breathing, coughing, sneezing or even simply speaking, with greater risk of spread indoors where we normally spend more than 80% of our time.

The most recent recommendations from WHO (Roadmap to improve and ensure good indoor ventilation in the context of COVID-19, March 1st, 2021) and the Prime Ministerial Decrees issued by the Italian Government (Guide Lines on Re-Opening Manufacturing) require, where possible, increasing the filtering efficiency of the equipment that handles indoor air and especially on air conditioning units in order to remove the smallest potentially infected particles from the air (containing pathogenic agents).

It is therefore suitable for different types of buildings, for example schools, hospitals and care homes, (hallways, waiting rooms, hospital ward rooms), doctor's offices, hotels and everywhere it is necessary to improve the quality of the indoor air.

### Advantages of the Crystall Duct System

- Multiple applications thanks to reduced overall dimensions (especially on existing systems)
- No impact on the thermal and aeraulic balance of the system
- Negligible pressure drops (even with dirty filter)
- Proven bactericidal action (sustainable IAQ)
- Simple and economic maintenance (cleaning the header without replacement and disposal expenses)
- Very low electric absorption
- Performance certified according to product standards UNI EN ISO 16890:2017 and UNI 11254:2007
- Compliant with the standards in force for electromagnetic compatibility and safety (by accredited agencies)
- Technologically sustainable and patented solution

## Tests and Certifications

The Crystall solution has gone through numerous tests and efficiency and efficacy testing to assess its function and performance level in real conditions of use.

At various accredited agencies, efficiency and pressure drop tests were conducted, according to product standards UNI EN ISO 16890:2017 and UNI 11254:2007 that are able to classify performance.

Sabiana's Crystall active electrostatic filter, duly sized, is able to guarantee a Most Penetrating Particle Size filtering efficiency level (MPPS - i.e. with an aeraulic diameter between 0.2 and 0.4  $\mu\text{m}$ ) equal to semi-absolute filter E11 (MPPS  $\geq$  95% - E11 @ UNI EN 1822-1).

Also, the **University of Ancona** (the online scientific publication "Bacteria Removal and Viability Attenuation by Means of an Electrostatic Barrier" can be consulted by purchasing the Indoor and Built Environment magazine from the website) conducted more than 180 laboratory tests on microbiological substances (total airborne microbiological load), which include bacteria, mould, fungi, etc. and that confirmed, through the statistical processing of the data carried out with the specific Fischer test, the efficacy of the Crystall active electrostatic filter in reducing the bacterial load.

## Main components of the Crystall filtering unit

The first element is the Crystall active electrostatic unit with aluminium modular cells which is composed of two separate and distinct sections, one of which is active (polarisation section) attached to the load-bearing structure and the other is passive, with induced anode (collection or header section) that can be removed for maintenance. The first section composed of electrodes and insulating parts does not require maintenance, while the second section, intended for the collection of organic and inorganic particulate, requires periodic cleaning. Its extremely contained depth (just 50 mm) combined with its great dimensional flexibility, make it suitable for satisfying the most diverse construction requirements, that have the aim of obtaining a high filtering level of the recirculation/secondary air (according to the definition provided by standard UNI EN 16798.3). The external metal frame of the polarisation section becomes the main component of the structure, that defines the installation typology and allows a fully customization and total adaptability, above all with pre-existent installations. The second component is the wired control and power box, available "fitted on the unit" or at a distance, that allows the management and the inspection of the Crystall filtering unit operating status.



### Femec active electronic plate filter

The Crystall active electrostatic filter is based on the principle of separation of the particles contained in the air through electrical polarisation and their subsequent treatment on counterposed metal surfaces, with opposite polarity. It is built with thin metal blades tapered together, forming numerous and intense electrical fields. The polluting particles that transit there, charged by a special electrode, are attracted and captured, as though by small magnets, on the counterposed surfaces of the blades. The power required for this process is low, approximately 4/7 W for every 1000 m<sup>3</sup>/h of handled air. Sabiana's patented Crystall solution makes it possible to achieve electrical fields on opposing surfaces without the need for additional electrical power supply, making every zone of the header (collection section) independent, thereby preventing the accidental short circuit of one section from compromising the operation of the entire filter.

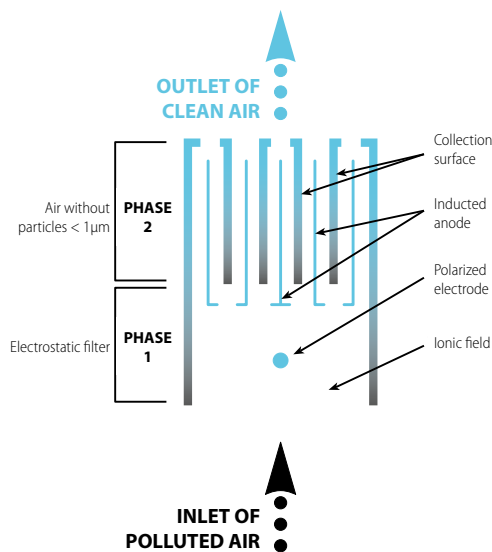

### Wired control and power box

The main element is the high voltage electronic power board required to feed the Crystall active electrostatic filter, an on/off disconnecting switch and a LED light to locally monitor the correct operating status; this switch can also be controlled remotely through an SPDT relay contact. The operating power supply is 230 Vac 50/60 Hz.



### Silicone cable and high voltage connectors

The wired box in the configuration at a distance requires the supply of a special cable with silicone insulation and relative connectors suitable for use with high voltage.



# Crystall Duct System CDS.C | CDS-C FILTER

This type of plenum was specifically designed to be inserted on duct connection branches, typically upstream of the distribution terminals for the purification of secondary recirculation air.

The structure is built with galvanised sheet metal, suspended, and is set up for coupling to flanged ducts. Inside it contains the Crystall active electrostatic section composed of one or more filtering units, depending on the selected model.

The inclusion of a hinged inspection door, located at the bottom of the plenum, provides easy access to the structure for all ordinary and extraordinary maintenance operations.

The supply is completed with a wired box that can be positioned either on the plenum (on the right or on the left shoulder as needed) or at a distance, a local LED that signals the operating status (also replicated on the box in in the configuration at a distance) and a safety microswitch located on the inspection door for the purpose of cutting off the power supply prior to access.

## Dimensions

**CDS.C1**

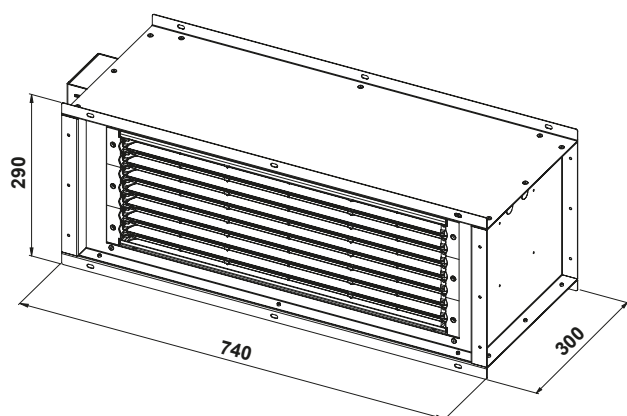

**CDS.C2**

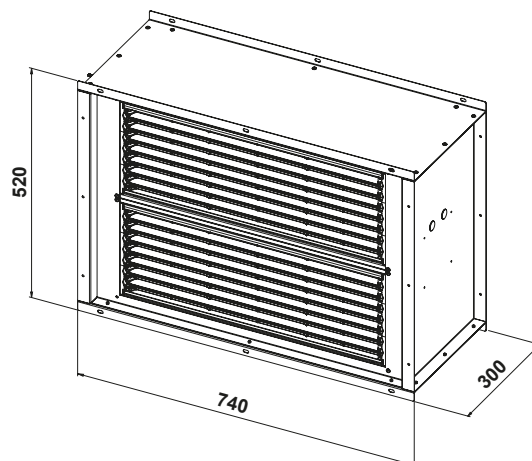

Model	Flow rate (m <sup>3</sup> /h)	$\Delta_{pi}$ Electrostatic filter (Pa)	$\Delta_{pi}$ Electrostatic filter + Coarse (Pa)	Efficiency class (**)
<b>CDS.C1</b>	500	1	19	ePM <sub>1</sub> 95% - ePM <sub>2,5</sub> 95% - ePM <sub>10</sub> 95% - MPPS 96% (E11 @ UNI EN 1822-1)
<b>CDS.C1</b>	650	1	26	ePM <sub>1</sub> 90% - ePM <sub>2,5</sub> 90% - ePM <sub>10</sub> 90% - MPPS 85% (E10 @ UNI EN 1822-1)
<b>CDS.C1</b>	1000*	2	43	ePM <sub>1</sub> 80% - ePM <sub>2,5</sub> 80% - ePM <sub>10</sub> 85% - MPPS 63%
<b>CDS.C1</b>	1300	3	59	ePM <sub>1</sub> 70% - ePM <sub>2,5</sub> 75% - ePM <sub>10</sub> 80% - MPPS 60%
<b>CDS.C2</b>	1000	2	20	ePM <sub>1</sub> 95% - ePM <sub>2,5</sub> 95% - ePM <sub>10</sub> 95% - MPPS 96% (E11 @ UNI EN 1822-1)
<b>CDS.C2</b>	1300	3	27	ePM <sub>1</sub> 90% - ePM <sub>2,5</sub> 90% - ePM <sub>10</sub> 90% - MPPS 85% (E10 @ UNI EN 1822-1)
<b>CDS.C2</b>	2000*	5	44	ePM <sub>1</sub> 80% - ePM <sub>2,5</sub> 80% - ePM <sub>10</sub> 85% - MPPS 63%
<b>CDS.C2</b>	2600	7	62	ePM <sub>1</sub> 70% - ePM <sub>2,5</sub> 75% - ePM <sub>10</sub> 80% - MPPS 60%

(\*) Recommended nominal air flow rate to obtain an ePM<sub>1</sub> high efficiency class

(\*\*) Performing test according the UNI EN ISO 16890:2017

**SFG Coarse filter section ISO Coarse 60% (ex G4) for CDS.C1**

Section made of galvanized steel containing a filtering cell with synthetic medium of flame retardant polyester F1 DIN 53438 class, usable as pre-filtration phase and separation of the coarse particles within the fresh air or processed air handling. The combination with the CDS.Cx section occurs by means of flanges provided upstream of this late one. ISO Classification Coarse 60% @ UNI EN ISO 16890 (ex G4 @ EN 779:2012).

**SFG1**

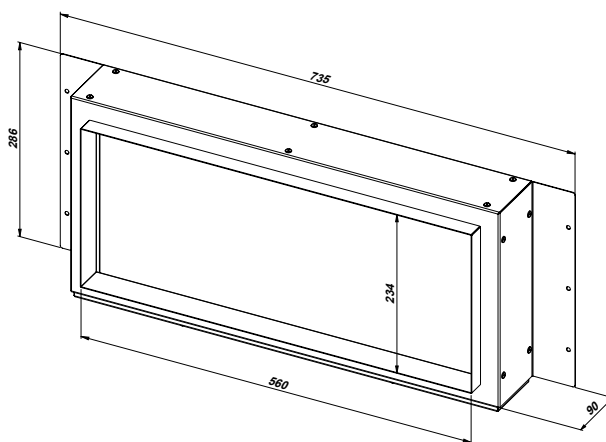

**SFG2**

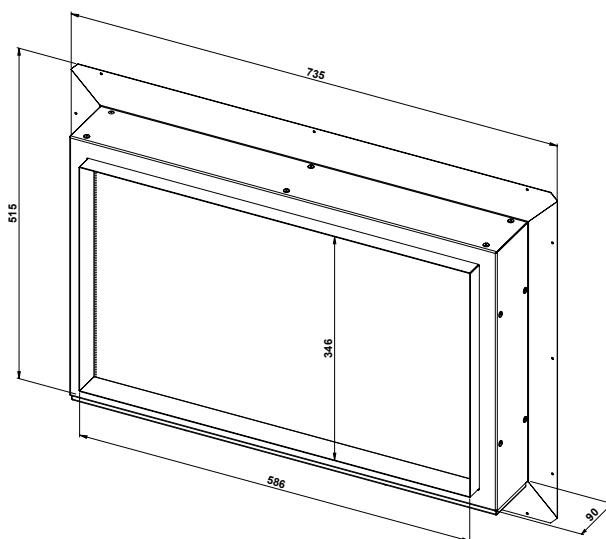



A company of Arbonia Group  
**ARBONIA** ▲

Follow us on



Sabiana app



---

**SABIANA SpA**

Società a socio unico

Via Piave 53 - 20011 Corbetta (MI) Italia

T. +39 02 97203 1 r.a. • F. +39 02 9777282

info@sabiana.it

**www.sabiana.it**