



Crystal Round

Electrostatic filter

Crystall Round

Electrostatic filter



Crystall Round is an electrostatic product range for the mechanical ventilation in either installation types: residential and tertiary.

The solution is designed for installations within the sector of VMC systems with flow rate until 600 m³/h and pre-installed circular spigots (from DN125 to DN180).

The Crystall Round range is equipped with Crystall 50 active electrostatic filtration (Sabiana patent) able to clean the fresh air with high efficiency class (ePM1 95% @ EN ISO 16890:2016) also in the presence of microparticulates with a diameter included between 0,2 - 0,4 micron (called MPPS - Most Penetrating Particle Size) with the same performance levels of a semi-absolute filter of E10 / E11 class. In this way the consumers belonging to the adjacent indoor ambients are provided with fresh and cleaned air during all the operating period of the VMC system.

The electrostatic filters allow a very high air cleaning by stopping and thus removing all the solid and liquid microparticles that can diffuse pathogenic substances dangerous to humans (virus and bacteria included) , that can reach until 0,1 micron of dimension. All this without causing any air side pressure drop or elevated power consumption. Moreover these filters can be easily regenerated (simple collector cleaning) without waste disposals and with low maintenance costs.

The Crystall Round filters are ultra-flat-shaped, designed for any type of installation within the residential false ceilings with classic standard dimensions, preferably for maintenance rooms where it is possible to install inspection openings. As the filter front panel can be half opened or totally removed, the unit can be mounted near the inner surface of the false ceiling.

For these reasons the Crystall Round can be considered a precious compact component for any residential ventilation system that safeguards very quietly the healthy and the aesthetic sense.

The unit is equipped with an air cleaning system that allows to separate the gas inlet flow from the polluting particles. The particles can be both solid or liquid. The electrostatic filter is single phase 230 V 50 Hz supply.

Filtering pad

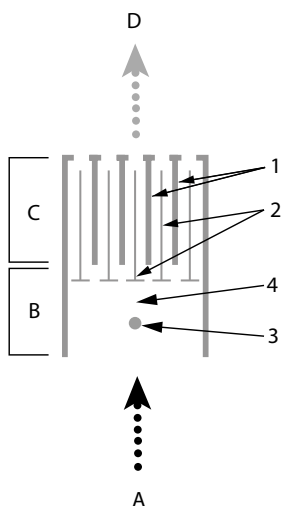

- A Polluted air inlet
- B Phase 1
- C Phase 2
- D Clean air outlet
- 1 Collection surface
- 2 Induced anode
- 3 Polarized electrode
- 4 Ionic field

Filter

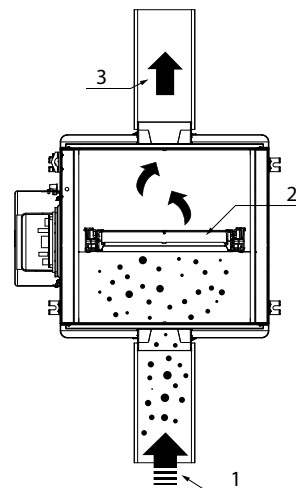

- 1 External polluted air intake
- 2 Electrostatic filter
- 3 Clean air supply

Phase 1

The smallest particles included in the aspirated air are exposed to an intensive ionizing field and are polarized.

Phase 2

The charged particles passing through the second filter section are pushed back by the anode and attracted to the collection surfaces by a strong, induced magnetic field.

The air which leaves the unit is free from polluting particles.

MAIN COMPONENTS

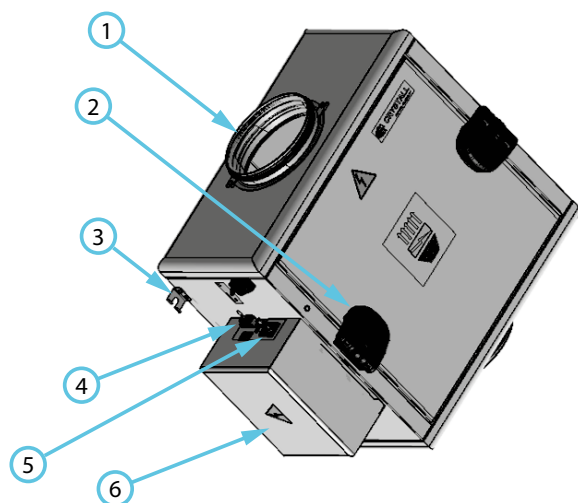

- 1 Connection spigot with garnish
- 2 Watertight handles for panel half opening or removal
- 3 Wall or ceiling brackets
- 4 Terminal board with contacts (control/alarm)
- 5 C14 connector
- 6 Electrical box

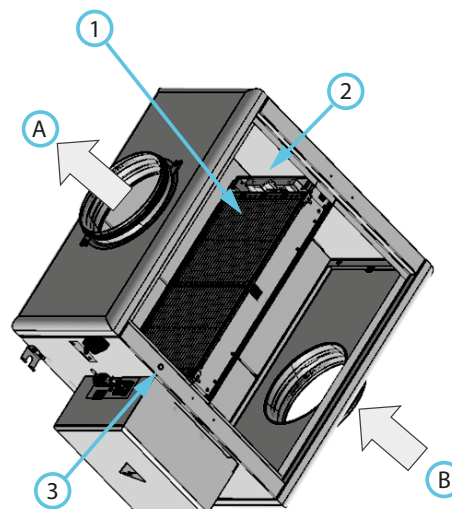

- A Purified air
- B Air to purify
- 1 Electrostatic filtering pad
- 2 Handles for the filtering pad removal in the direction of the air flow
- 3 LED operative status

Valid data for the standard version and for the version with DX installation (CR-200-D - CR-400-D - CR-600-D)

Model		CR- 200	CR- 400	CR- 600
ISO 16890 Filtration Efficiency		90% ≤ ePM ₁ < 95%	80% ≤ ePM ₁ < 90%	80% ≤ ePM ₁ < 90%
Max. flow rate	m ³ /h	200	400	600
Power supply	V/Hz	230/50	230/50	230/50
Power absorption	W	12	12	12

Filter class efficiency according to the EN 16890

Model	Flow rate (m ³ /h)	Efficiency class (EN ISO 16890)			MPPS*
CR-200	190	ePM ₁ 95%	ePM _{2,5} 95%	ePM ₁₀ 95%	MPPS 96% (E11 @ EN 1822-1)
	240	ePM ₁ 90%	ePM _{2,5} 90%	ePM ₁₀ 90%	MPPS 85% (E10 @ EN 1822-1)
CR-400	280	ePM ₁ 95%	ePM _{2,5} 95%	ePM ₁₀ 95%	MPPS 96% (E11 @ EN 1822-1)
	370	ePM ₁ 90%	ePM _{2,5} 90%	ePM ₁₀ 90%	MPPS 85% (E10 @ EN 1822-1)
	490	ePM ₁ 80%	ePM _{2,5} 85%	ePM ₁₀ 85%	MPPS 69%
CR-600	410	ePM ₁ 95%	ePM _{2,5} 95%	ePM ₁₀ 95%	MPPS 96% (E11 @ EN 1822-1)
	530	ePM ₁ 90%	ePM _{2,5} 90%	ePM ₁₀ 90%	MPPS 85% (E10 @ EN 1822-1)
	710	ePM ₁ 80%	ePM _{2,5} 85%	ePM ₁₀ 85%	MPPS 69%

Dimension of the most penetrating particle (Most penetrating particle size)

Dimensions

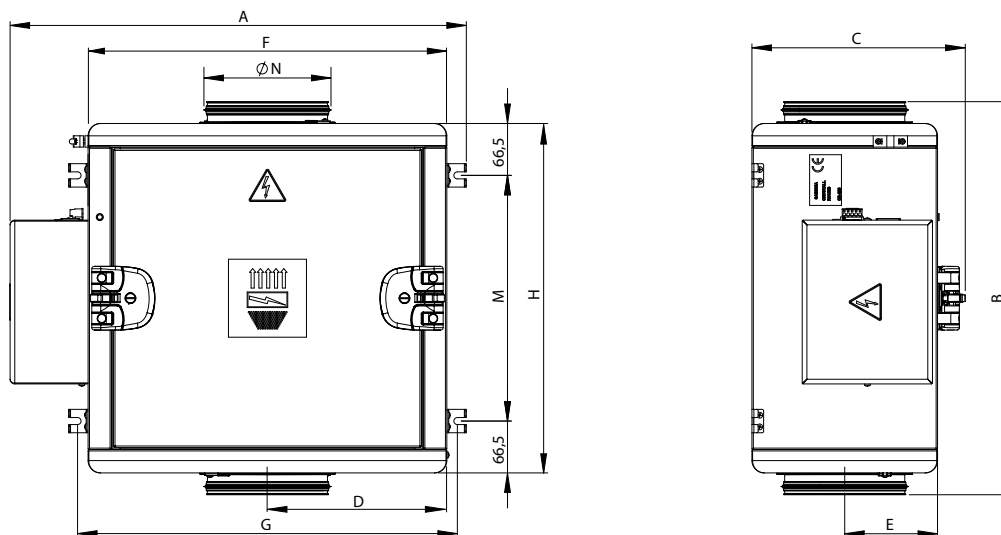

Left version dimension; for the right versions the dimensions are symmetrical.

Model		CR- 200	CR- 400	CR- 600
A	mm	585	585	705
B	mm	504	504	673
C	mm	218	274	292
D	mm	230	230	250
E	mm	91	119	128
F	mm	460	460	580
G	mm	487	487	607
H	mm	448	448	600
M	mm	315	315	467
ØN	"	125	160	180

Combinations with Energy Smart for wall on board installation

Crystall Round units are designed to be applied on the main duct for the fresh air supply distribution, installed downstream of the VMC unit and at a distance from it, between the air inlet grid and the ramification plenum of the plant. Given the flattened shape of the units, the standard application is in a false ceiling, near the previously mentioned plenums. However, there is a possibility of a wall or double-wall application at a distance. In case of application at a distance from the VMC unit, the installation of the Crystall Round unit on the right or on the left depends on the specific need of the installation type.

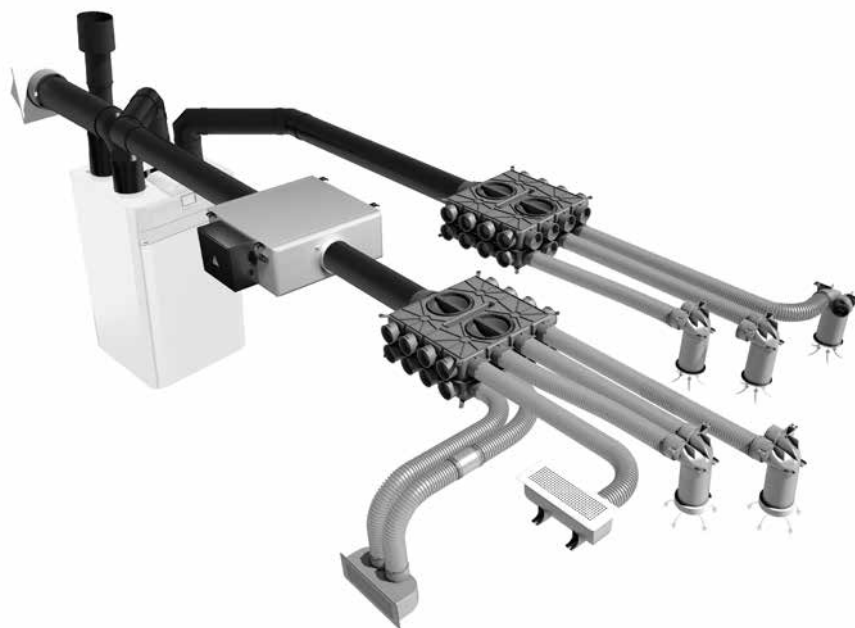

Combinations with Energy Smart

The typical case for this combination type is the wall installation for Energy Smart (S/SP) units with floor/wall support and on vertical position and for flat Energy Smart units (SHP) is the ceiling/wall installation.

Recommended combination of the Crystall Round version with the Energy Smart S/SP vertical version

Model	Energy Smart Left external air connection	Energy Smart Right external air connection
ENY-S-170	CR200-D*	CR200
ENY-SP-180		
ENY-S-270	CR400-D*	CR400
ENY-SP-280		
ENY-S-360		
ENY-SP-370	CR600-D*	CR600
ENY-S-460		
ENY-SP-460		
ENY-S-600		
ENY-SP-600		

Recommended combination of the Crystall Round version with the Energy Smart SHP horizontal and vertical version

Modello	Energy Smart Left external air connection	Energy Smart Right external air connection
ENY-SHP-130	N/A	CR200*
ENY-SHP-150	N/A	CR200*
ENY-SHP-170**	CR200-D	CR200*

* Standard application without Energy Smart unit electronic board setup changes.
 ** Crystall Round accessory remote installation is recommended for ENY-SHP-170 unit.



A company of Arbonia Group
ARBONIA ▲

Follow us on



Sabiana app

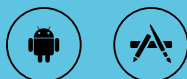

SABIANA SpA

Società a socio unico

Via Piave 53 - 20011 Corbetta (MI) Italia

T. +39 02 97203 1 r.a. • F. +39 02 9777282

info@sabiana.it

www.sabiana.it